

## Specification Information Sheet

### RT075L

RainTrak 75mm wide, variable depth channel with Linéaire grate

#### Specification clause

The floor channel and grates are to be type RT075L (75mm wide, variable depth channel with Linéaire grates) grade 304/316 stainless steel, as supplied by ACO Pty Ltd.

The channels overall depth, length, outlet position/s and outlet diameter/s are specified on drawing number/s \_\_\_\_\_.

All components used within the scope of the systems are shown on drawing number/s \_\_\_\_\_. All work should be carried out strictly in accordance with the manufacturers instructions and the installation details set out on drawing number/s \_\_\_\_\_.

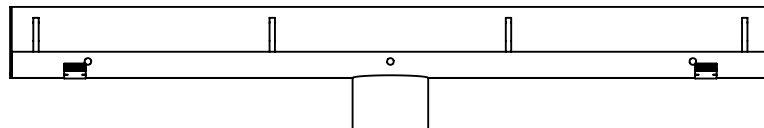
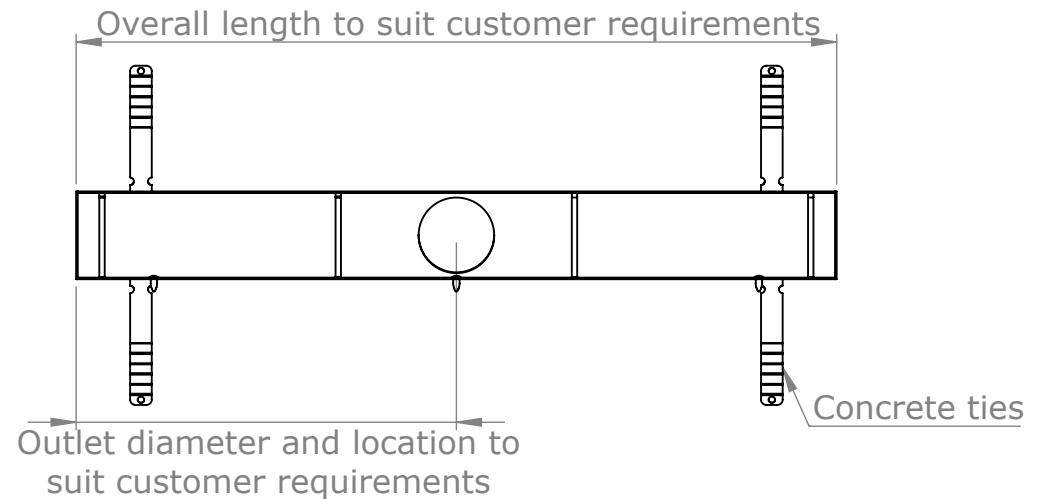
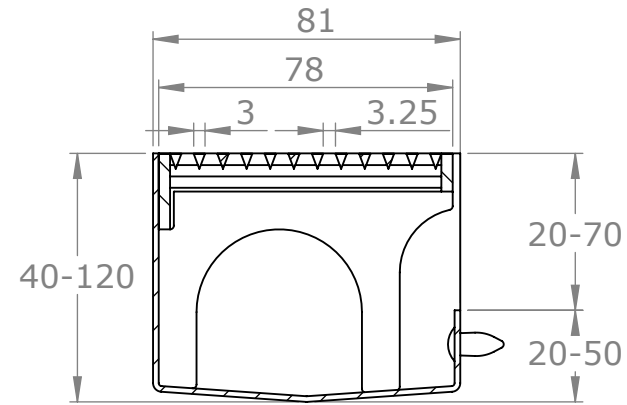

[www.acobuildline.com.au](http://www.acobuildline.com.au)

Ph: 1300 765 266 (Australia)

Ph: +61 2 4747 4000 (International)

\*All dimensions in mm