

Specification Information Sheet

S103-40-A

103mm wide, 40mm deep channel with Affiner grate (nominal)

Specification clause

The floor channel and grates are to be type S-103-40-A (103mm wide, 40mm deep channel with Affiner grates) grade 304/316 stainless steel, as supplied by ACO Pty Ltd.

Grates meet slip rating P1 (wet pendulum test) and A (wet barefoot test).

The channels overall length, outlet position and outlet diameters are specified on drawing number/s _____.

All components used within the scope of the systems are shown on drawing number/s _____. All work should be carried out strictly in accordance with the manufacturer's instructions and the installation details set out on drawing number/s ____.

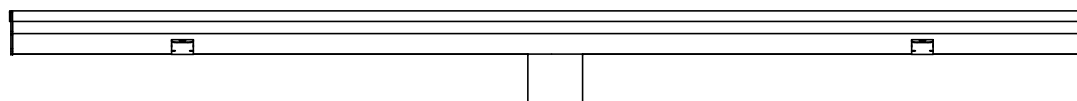
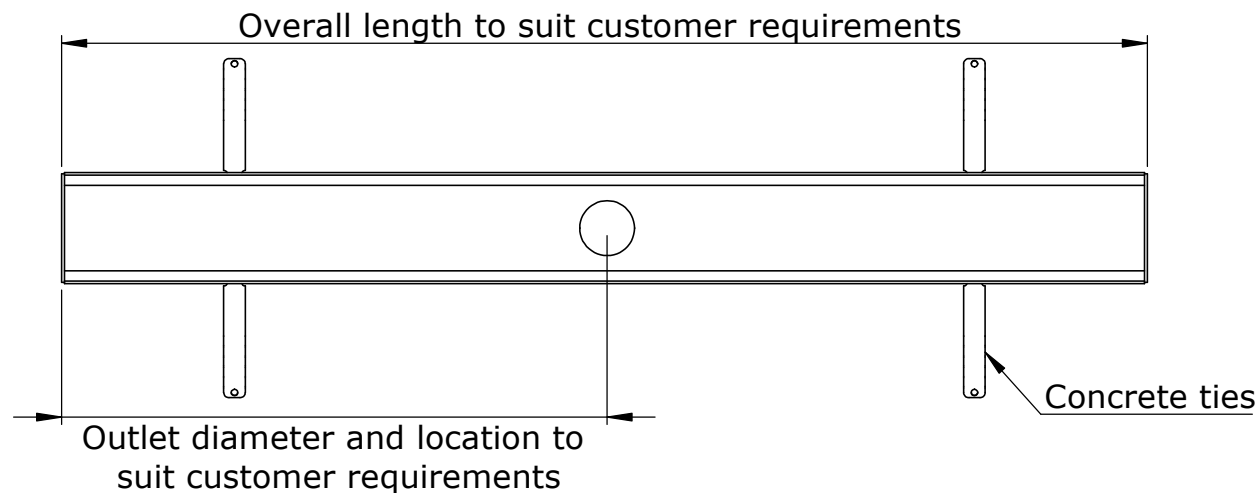
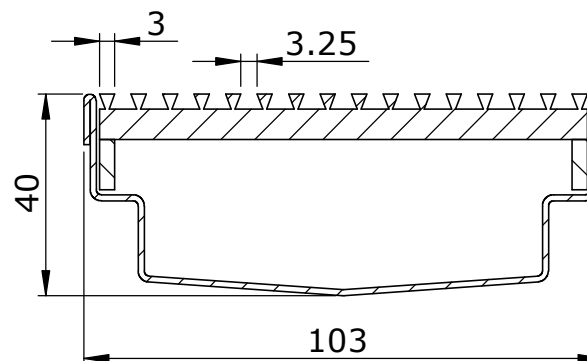

www.acobuildline.com.au
www.acoshowerdrain.com.au

Ph: 1300 765 266 (Australia)
 Ph: +61 2 4747 4000 (International)

*All dimensions in mm